



DEFENSE INFORMATION SYSTEMS AGENCY

P. O. BOX 4502
ARLINGTON, VIRGINIA 22204-4502

IN REPLY
REFER TO: Joint Interoperability Test Command (JTE)

9 Dec 08

MEMORANDUM FOR DISTRIBUTION

SUBJECT: Special Interoperability Test Certification of the Hewlett-Packard Integrity RX2660 Family of Servers Running the SUSE Linux Enterprise Server 10 Service Pack 2, Operating System for Internet Protocol Version 6 Capability

References: (a) DoDD 4630.5, "Interoperability and Supportability of Information Technology (IT) and National Security Systems (NSS)," 5 May 2004
(b) CJCSI 6212.01D, "Interoperability and Supportability of Information Technology and National Security Systems," 8 March 2006
(c) through (h), see Enclosure 1

1. References (a) and (b) establish the Joint Interoperability Test Command (JITC), as the responsible organization for interoperability test certification.
2. The Hewlett-Packard (HP) Integrity RX2660 server, running the SUSE Linux Enterprise Server 10 Service Pack (SP) 2 operating system (OS), met the Internet Protocol (IP) Version 6 (IPv6) Capable interoperability requirements for an advanced server as described in the Department of Defense (DoD) Information Technology Standards Registry, "DoD IPv6 Standard Profiles for IPv6 Capable Products Version 2.0," 1 August 2007, reference (c). This device has successfully completed the related IPv6 Interoperability portions of the "DoD IPv6 Generic Test Plan Version 3," August 2007, reference (d), and is certified for listing on the Unified Capabilities (UC) Approved Products List (APL) as IPv6 Capable. The HP Integrity RX2660 server, running the SUSE Linux Enterprise Server 10 SP 2 OS is of equivalent architecture to, and therefore a representative sample of the HP Integrity systems family which additionally includes the Integrity BL860c, BL870c, RX2xxx series, RX3xxx series, RX6xxx series, RX7xxx series, RX8xxx series, and Integrity Superdome series utilizing the Intel Itanium processor chip, and running the SUSE Linux Enterprise Server 10 SP 2 OS. This certification expires upon changes that could affect interoperability, but no later than 3 years from the date of this memorandum.
3. This special certification is based on IPv6 Capable Interoperability testing conducted by JITC at Fort Huachuca, Arizona, and the vendor's Letter of Conformance (LoC) dated 30 October 2008. Interoperability testing was conducted from 20 October through 7 November 2008, at JITC's Advanced IP Technology Capability. Conformance testing was confirmed by HP and was verified in the LoC provided. Enclosure 2 documents the summary test results and describes the devices. Users should verify interoperability before deploying the devices in an environment that varies significantly from that described.
4. The device's interoperability status summary is in Table 1, and Table 2 contains the equipment listing.

JITC Memo, JTE, Special Interoperability Test Certification of the Hewlett-Packard Integrity RX2660 Family of Servers Running the SUSE Linux Enterprise Server 10 Service Pack 2, Operating System for Internet Protocol Version 6 Capability

Table 1. Interoperability Status Summary

Hewlett-Packard Integrity RX2660 Server		
Functional Category	Requirement	Verified
Base IPv6	M	Yes
IPSec	M	Yes
Transition Mechanisms	S	Yes
Quality of Service	O	No
Mobility	CM	No
Bandwidth Limited Networks	O	No
Server	O	Yes
Host	M	Yes
LEGEND:		
CM	Conditional Must	M Must
IPSec	Internet Protocol Security	O Optional
IPv6	Internet Protocol Version 6	S Should
NOTE: The terms Conditional Must, Must, Should, and Optional are used to reference specifically required Request for Comments from the Internet Engineering Task Force, the Department of Defense Information Technology Standards Registry, and the Department of Defense Internet Protocol Version 6 Generic Test Plan.		

Table 2. Equipment Listing

Hewlett-Packard Integrity RX2660 Server		
Component	Firmware/Software	Interface
Hewlett-Packard Integrity RX2660 Server	SUSE Linux Enterprise Server 10 SP 2	RJ45 Gigabit Ethernet
LEGEND:		
10	10 Mbps	Mbps Megabits per second
100	100 Mbps	SP Service Pack
Base	Baseband	T Ethernet over Twisted-pair

5. No detailed test report was written in accordance with guidance from the Assistant Secretary of Defense-Networks Information and Integration. JITC distributes interoperability information via the JITC Electronic Report Distribution (ERD) system, which uses Unclassified-But-Sensitive Internet Protocol Router Network (NIPRNet) e-mail. More comprehensive interoperability status information is available via the JITC System Tracking Program (STP). The STP is accessible by .mil/gov users on the NIPRNet at <https://stp.fhu.disa.mil>. Test reports, lessons learned, and related testing documents and references are on the JITC Joint Interoperability Tool (JIT) at <http://jit.fhu.disa.mil> (NIPRNet), or <http://199.208.204.125> (SIPRNet). Information related to IPv6 Capable testing is on the UC APL at http://jitc.fhu.disa.mil/adv_ip/register/register.html.

JITC Memo, JTE, Special Interoperability Test Certification of the Hewlett-Packard Integrity RX2660 Family of Servers Running the SUSE Linux Enterprise Server 10 Service Pack 2, Operating System for Internet Protocol Version 6 Capability

6. The JITC point of contact is Donald L. Hann, DSN 879-5130, commercial (520) 538-5130, or e-mail don.hann@disa.mil.

FOR THE COMMANDER:



2 Enclosures a/s

for RICHARD A. MEADOR
Chief
Battlespace Communications Portfolio

Distribution (electronic mail):

Joint Staff J-6

Joint Interoperability Test Command, Liaison, TE3/JT1

Office of Chief of Naval Operations, CNO N6F2

Headquarters U.S. Air Force, Office of Warfighting Integration & CIO, AF/XCIN (A6N)

Department of the Army, Office of the Secretary of the Army, DA-OSA CIO/G-6 ASA (ALT), SAIS-IOQ

U.S. Marine Corps MARCORSSYSCOM, SIAT, MJI Division I

DOT&E, Net-Centric Systems and Naval Warfare

U.S. Coast Guard, CG-64

Defense Intelligence Agency

National Security Agency, DT

Defense Information Systems Agency, TEMC

Office of Assistant Secretary of Defense (NII)/DOD CIO

U.S. Joint Forces Command, Net-Centric Integration, Communication, and Capabilities Division, J68

DITO, Defense Information Systems Agency (DISA), Attn: GE36, P.O. Box 4502, Arlington, VA 22204-4502

Hewlett-Packard Company, Attn: Adam Silveira, 8000 Foothills Blvd, Roseville, CA 95678

ADDITIONAL REFERENCES

- (c) Department of Defense (DoD) Information Technology Standards Registry (DISR), "DoD Internet Protocol Version 6 (IPv6) Standard Profiles for IPv6 Capable Products Version 2.0," 1 August 2007
- (d) Defense Information Systems Agency, Joint Interoperability Test Command, "DoD IPv6 Generic Test Plan Version 3," August 2007
- (e) DoD Chief Information Officer (CIO) Memorandum, "IPv6," 9 June 2003
- (f) DoD CIO Memorandum, "IPv6 Interim Transition Guidance," 29 September 2003
- (g) DoD IPv6 Transition Office, "DoD IPv6 Master Test Plan, Version 2," September 2006
- (h) DoD, "DISR Global Information Grid (GIG) Convergence Master Plan (GCMP), Version 5.25," 29 March 2006

INTERNET PROTOCOL VERSION 6 CAPABLE TESTING SUMMARY

- 1. SYSTEM TITLE.** The Hewlett-Packard (HP) Integrity RX2660 Server running the SUSE Linux Enterprise Server 10 Service Pack 2 operating system (OS), hereafter referred to as the device under test (DUT).
- 2. PROPONENT.** Department of Defense (DoD) Internet Protocol (IP) Version 6 (IPv6) Transition Office (DITO).
- 3. PROGRAM MANAGER/USER POC.** DITO, Defense Information Systems Agency (DISA), Attn: GE36 Sam Assi, P.O. Box 4502, Arlington, VA 22204-4502, (703) 882-0241, e-mail: sam.assi@disa.mil.
- 4. TESTER.** Donald L. Hann, Joint Interoperability Test Command (JITC), P.O. Box 12798, Fort Huachuca, AZ 85670-2798, DSN: 879-5130, commercial: (520) 538-5130, e-mail: don.hann@disa.mil.
- 5. DEVICE UNDER TEST DESCRIPTION.** The DUT was an enterprise server, designed by HP to offer a unique combination of scalability, virtualization, and availability.
- 6. OPERATIONAL ARCHITECTURE.** The operational architecture was the JITC simulated Defense Information Systems Network (DISN) IP Core Network as depicted in Figure 2-1.
- 7. REQUIRED DEVICE INTERFACES.** All IPv6-capable products to be included on the Unified Capabilities Approved Product List must meet the requirements of the DoD Information Technology Standards Registry (DISR), "DoD IPv6 Standard Profiles for IPv6 Capable Products Version 2.0," 1 August 2007. Product testing conducted against these requirements is in accordance with the "DoD IPv6 Generic Test Plan (GTP) Version 3," August 2007. The IPv6 advanced server profile requirements for conformance and interoperability are in Table 2-1.

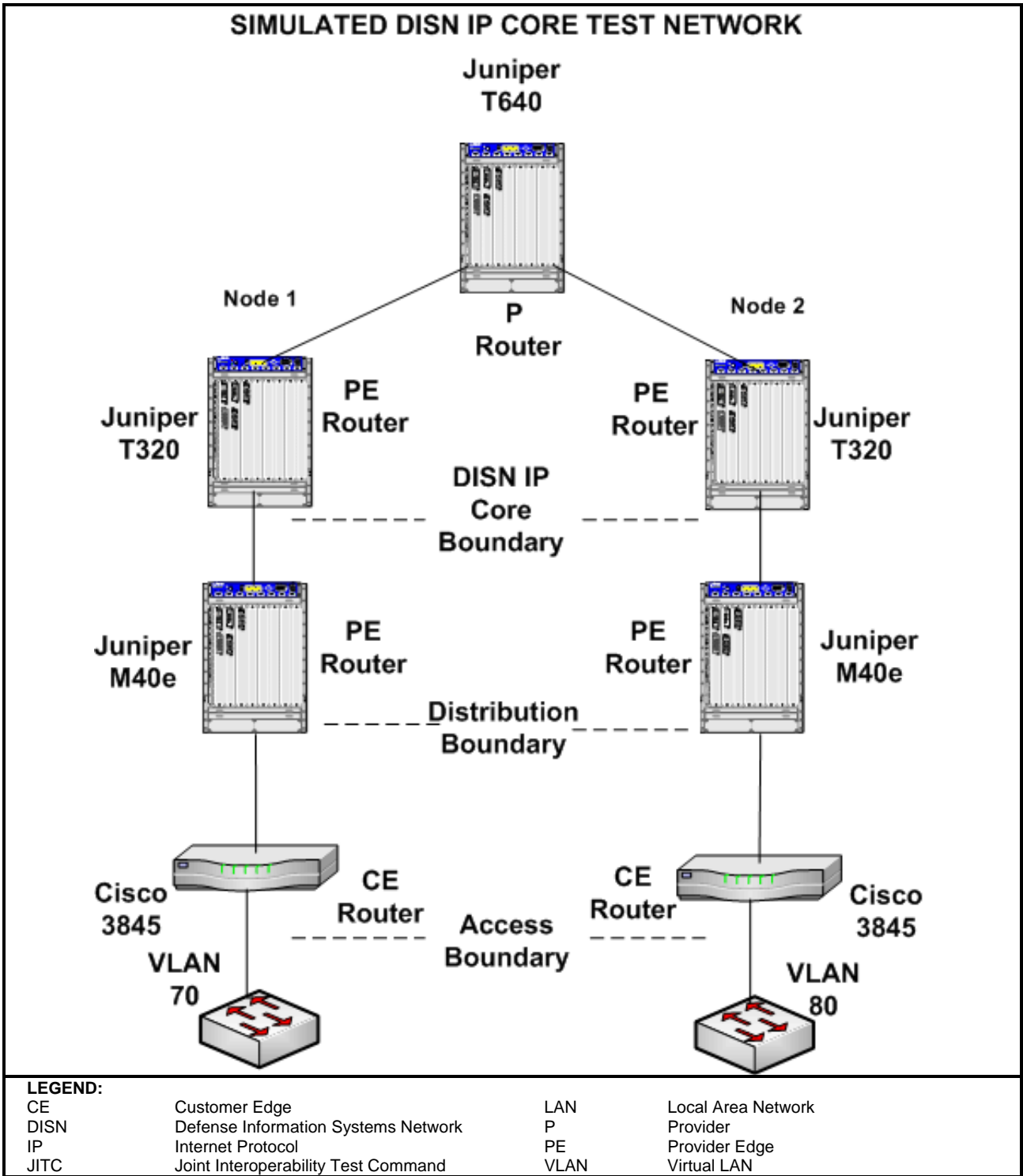

Figure 2-1. JITC Simulated DISN IP Core Network

Table 2-1. IPv6 Capability Requirements and Status

Hewlett-Packard Integrity RX2660 Server							
RFC	RFC Title	Testing Completed		Advanced Server		Implemented	Comments
		Conformance	Interoperability	Requirement	Met/Not Met		
IPv6 Base							
2460	Internet Protocol version 6 (IPv6) Specification	Stated in LoC	Yes	M	Met	Yes	
4443	Internet Control Message Protocol (ICMPv6) for the Internet Protocol Version 6 (IPv6) Specification	Stated in LoC	Yes	M	Met	Yes	
2461	Neighbor Discovery for IP version 6 (IPv6)	Stated in LoC	Yes	M	Met	Yes	
1981	Path Maximum Transmission Unit Discovery for IPv6	Stated in LoC	Yes	M	Met	Yes	
2462	IPv6 Stateless Address Auto configuration	Stated in LoC	Yes	M	Met	Yes	Note 1
3315	DHCPv6 (Client)	Stated in LoC	Yes	M	Met	Yes	Note 1
4291	IPv6 Addressing Architecture	Stated in LoC	Yes	M	Met	Yes	
4007	IPv6 Scoped Address Architecture	Stated in LoC	Yes	M	Met	Yes	
4193	Unique Local IPv6 Unicast Addresses	Stated in LoC	Yes	M	Met	Yes	
2710	Multicast Listener Discovery (MLD)	Stated in LoC	Yes	M	Met	Yes	
3810	Multicast Listener Discovery Version 2 (MLDv2) for IPv6	Stated in LoC	Yes	M	Met	Yes	
2464	Transmission of IPv6 Packets over Ethernet Networks	Stated in LoC	Yes	CM	Met	Yes	
IPSec							
4301	Security Architecture for the Internet Protocol	Stated in LoC	Yes	M	Met	Yes	
4302	IP Authentication Header	Stated in LoC	Yes	S	Met	Yes	
4303	IP Encapsulating Security Payload (ESP)	Stated in LoC	Yes	M	Met	Yes	
4304	Extended Sequence Number (ESN) Addendum to IPsec Domain of Interpretation (DOI) for Internet Security Association and Key Management Protocol (ISAKMP)	Not Stated	Not Tested	S	Not Tested	No	
4305	Cryptographic Algorithm Implementation Requirements for Encapsulating Security Payload (ESP) and Authentication Header (AH)	Stated in LoC	Yes	M	Met	Yes	
4869	Suite B Cryptographic Suites for IPsec	Not Stated	Not Tested	S+	Not Tested	No	
4308	Cryptographic Suites for IPsec	Stated in Loc	Yes	None	Met	Yes	
4309	Using Advanced Encryption Standard (AES) CCM Mode with IPsec Encapsulating Security Payload (ESP)	Not Stated	Not Tested	CS	Not Tested	No	
3041	Privacy Extensions for Stateless Address Auto configuration in IPv6	Stated in LoC	Yes	S+ CM	Met	Yes	

Table 2-1. IPv6 Capability Requirements and Status (continued)

Hewlett-Packard Integrity RX2660 Server							
RFC	RFC Title	Testing Completed		Advanced Server		Implemented	Comments
		Conformance	Interoperability	Requirement	Met/Not Met		
3971	Secure Neighbor Discovery	Not Stated	Not Tested	S	Not Tested	No	
3972	Cryptographically Generated Addresses	Not Stated	Not Tested	S	Not Tested	No	
4306	Internet Key Exchange (IKEv2) Protocol	Stated in LoC	Yes	M	Met	Yes	
4307	Cryptographic Algorithms for Internet Key Exchange Version 2 (IKEv2)	Stated in LoC	Yes	M	Met	Yes	
Transition Mechanisms							
4213	Transition Mechanisms for IPv6 Host and Routers	Stated in LoC	Yes	CM	Met	Yes	
2766	Network Address Translation – Protocol Translation (NAT-PT)	Not Stated	Not Tested	SN	Not Tested	No	
3053	IPv6 Tunnel Broker	Not Stated	Not Tested	CM	Not Tested	No	
QoS							
2474	Definition of the Differentiated Services Field (DS Field) in the IPv4 and IPv6 Headers	Not Stated	Not Tested	O	Not Tested	No	
2205	Resource ReSerVation Protocol (RSVP) – Version 1 Functional Specification	Not Stated	Not Tested	O	Not Tested	No	
2207	RSVP Extensions for IPSEC Data Flows	Not Stated	Not Tested	O	Not Tested	No	
2210	The Use of RSVP with IETF Integrated Services	Not Stated	Not Tested	O	Not Tested	No	
2750	RSVP Extensions for Policy Control	Not Stated	Not Tested	O	Not Tested	No	
3175	Aggregation of RSVP for IPv4 and IPv6 Reservations	Not Stated	Not Tested	O	Not Tested	No	
Mobility							
3775	Mobility Support in IPv6	Not Stated	Not Tested	CM	Not Tested	No	
Bandwidth Limited Networks							
3095	Robust Header Compression (RoHC)	Not Stated	Not Tested	O	Not Tested	No	
3241	RoHC over PPP	Not Stated	Not Tested	O	Not Tested	No	
3843	RoHC: A Compression Profile for IP	Not Stated	Not Tested	O	Not Tested	No	
4362	RoHC: A Link-Layer Assisted Profile for IP/UDP/RTP	Not Stated	Not Tested	O	Not Tested	No	
2507	IP Header Compression	Not Stated	Not Tested	O	Not Tested	No	
2508	Compressing IP/UDP/RTP Headers for Low-Speed Serial Links	Not Stated	Not Tested	O	Not Tested	No	

Hewlett-Packard Integrity RX2660 Server							
RFC	RFC Title	Testing Completed		Advanced Server		Implemented	Comments
		Conformance	Interoperability	Requirement	Met/Not Met		
Server							
959	File Transfer Protocol	Stated in LoC	Yes	O	Met	Yes	
2428	FTP Extensions for IPv6 and NAT	Stated in LoC	Yes	O	Met	Yes	
2821	Simple Mail Transfer Protocol (SMTP)	Stated in LoC	Yes	O	Met	Yes	
2911	Internet Printing Protocol	Not Stated	Not Tested	O	Not Tested	No	
3162	RADIUS (Remote Authentication dial-In User Service) and IPv6	Not Stated	Not Tested	O	Not Tested	No	
2616	Hypertext Transfer Protocol – HTTP/1.1 – Web Server Role	Stated in LoC	Yes	None	Met	Yes	
4330	Simple Network Time Protocol (SNTP)	Stated in LoC	Yes	O	Met	Yes	
3226	DNS Security and IPv6 A6 Aware Server/Resolver Message Size Requirements	Not Stated	Not Tested	O	Not Tested	No	
3261	Session Initiation Protocol (SIP)	Not Stated	Not Tested	O	Not Tested	No	
3596	DNS Extensions to Support IPv6	Not Stated	Not Tested	O	Not Tested	No	
Host							
3484	Default Address Selection for IPv6	Stated in LoC	Yes	M	Met	Yes	
3596	DNS Extensions to Support IPv6	Stated in LoC	Yes	M	Met	Yes	
3986	Uniform Resource Identifier (URI): Generic Syntax	Stated in LoC	Yes	M	Met	Yes	
LEGEND:							
CBC	Cipher Block Chaining			M	Must		
CCM	CBC MAC Mode			MAC	Message Authentication Code		
CM	Conditional Must			NAT	Network Address Translation		
CS	Conditional Should			O	Optional		
DHCPv6	Dynamic Host Configuration Protocol Version 6			PPP	Point-to-Point Protocol		
DNS	Domain Name Service			QoS	Quality of Service		
DoD	Department of Defense			RADIUS	Remote Authentication dial-In User Service		
FTP	File Transfer Protocol			RFC	Request for Comment		
HTTP	Hypertext Transfer Protocol			RoHC	Robust Header Compression		
IETF	Internet Engineering Task Force			RSVP	Resource ReSerVation Protocol		
IP	Internet Protocol			RTP	Real-Time Transport Protocol		
IPSec	Internet Protocol Security			S	Should		
IPv4	Internet Protocol Version 4			SN	Should Not		
IPv6	Internet Protocol Version 6			S+	Should+		
LoC	Letter of Conformance			UDP	User Datagram Protocol		
NOTES:							
1. All Product Classes MUST support a method of autonomous configuration, either SLAAC or DHCPv6 client.							
2. The terms Must, Conditional Must, Should, Should+, Conditional Should, Conditional Should +, Should Not, and Optional are used to reference specific required RFCs from the IETF, the DoD Information Technology Standards Registry, and the DoD IPv6 Generic Test Plan.							

8. TEST NETWORK DESCRIPTION. The DUT was tested as part of the JITC simulated DISN IP Core Network managed by the Advanced IP Technology Capability, and configured as shown in Figure 2-2.

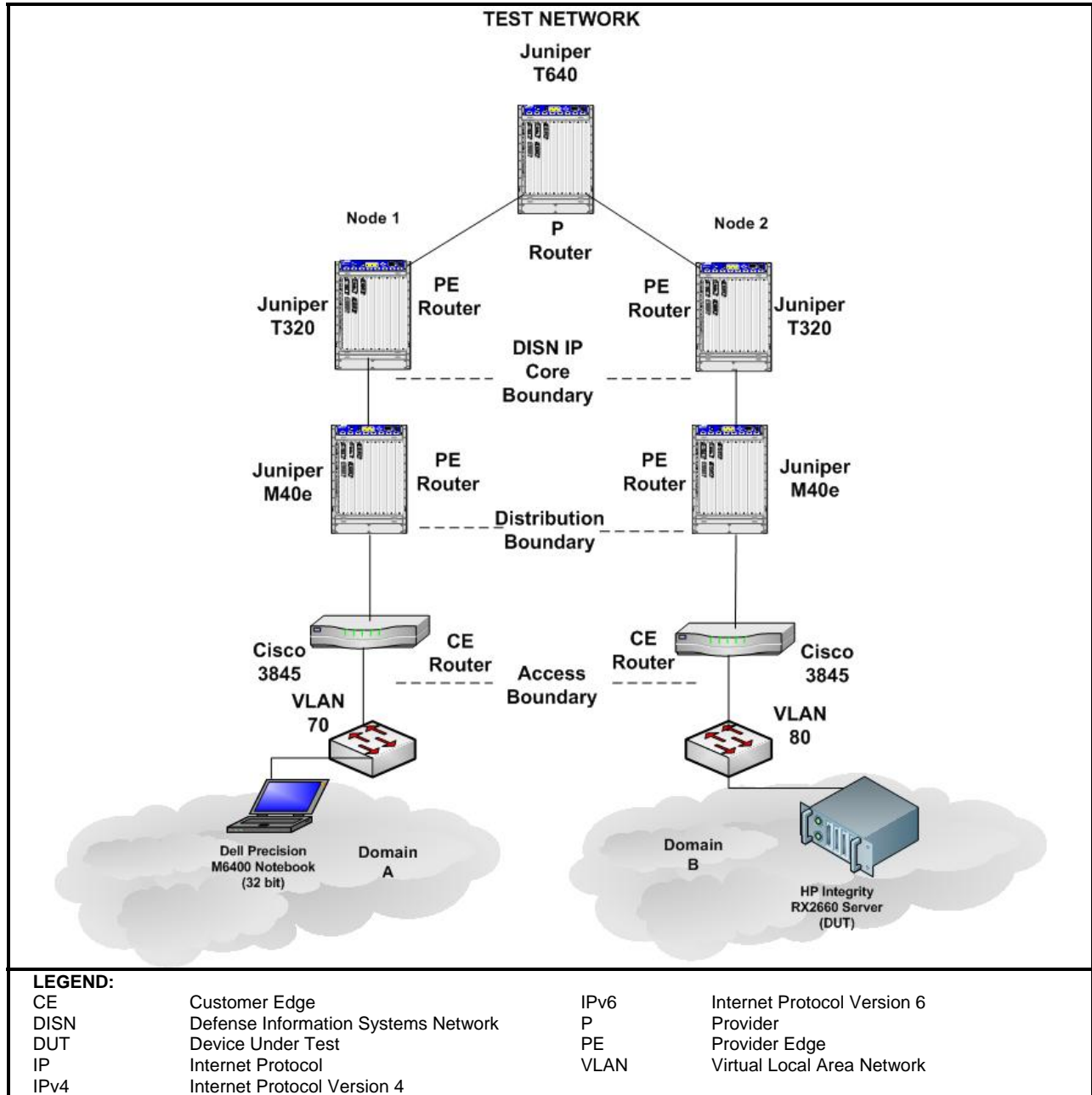

Figure 2-2. Test Network

9. DEVICE CONFIGURATIONS. Table 2-2 provides hardware and software components used in the test network.

Table 2-2. Test Configuration Hardware and Software

Equipment Name	Model Number	IOS/OS/Version(s)	
Hardware			
Hewlett-Packard Server - DUT	Integrity RX2660	SUSE Linux Enterprise Server 10	
2 Cisco Routers	Cisco 3845	12.4(11)T	
2 Juniper Routers	Juniper M40e	V 7.6R3.6	
2 Juniper Routers	Juniper T320	V 7.5R4.4	
Juniper Router	Juniper T640	V 7.5R4.4	
Dell Notebook	Precision M6400 (32 bit)	MS Windows Vista SP 1	
Software			
SUSE Linux Enterprise Server 10	N/A	SLES10_PSP_8.10 SP 2	
Microsoft Windows Vista	N/A	Build 6.0.6000 SP1	
Wireshark	N/A	V 0.99.2 (SVN Rev 18752)	
LEGEND:			
DUT	Device Under Test	Rev	Revision
IOS	Internetworking Operating System	SLES	SUSE Linux Enterprise Server
MS	Microsoft	SP	Service Pack
N/A	Not Applicable	SVN	Software Version Number
OS	Operating System	V	Version
R	Release		

10. TEST LIMITATIONS. None.

11. TEST RESULTS.

a. IPv6 Base.

Test Case C.1.2. The Request for Comments (RFC) 2460 IPv6 Specification is the base specification of the IPv6 protocol. It specifies a number of parameters that enable successful completion of IPv6 traffic addressing and control. The HP Integrity RX2660 server running the SUSE Linux Enterprise Server 10 SP 2 OS met the test requirement.

Test Case C.1.14. The RFC 4443 identifies Internet Control Message Protocol messages for the IPv6 protocol. It includes message format and identifies two types of messages: error and informational. The HP Integrity RX2660 server running the SUSE Linux Enterprise Server 10 SP 2 OS met the test requirement.

Test Case C.1.3. The RFC 2461 Neighbor Discovery for IPv6 specifies the neighbor discovery function that is similar to address resolution protocol in IP Version 4 (IPv4). It is necessary for implementing neighbor solicitations and neighbor advertisements within IPv6. The HP Integrity RX2660 server running the SUSE Linux Enterprise Server 10 SP 2 OS met the test requirement.

Test Case C.1.1. The RFC 1981 Path Maximum Transmission Unit Discovery for IPv6 is necessary for proper IPv6 implementations. It acts as a mechanism to determine the maximum size of packets to traverse the network without fragmentation. The HP Integrity RX2660 server running the SUSE Linux Enterprise Server 10 SP 2 OS met the test requirement.

Test Case C.1.4. The RFC 2462 IPv6 Stateless Address Auto-configuration specifies how a host auto-configures its interfaces in IPv6. These steps include determining whether the source addressing should be stateless or stateful, whether the information obtained should be solely the address or include other information, and Duplicate Address Detection. The HP Integrity RX2660 server running the SUSE Linux Enterprise Server 10 SP 2 OS met the test requirement.

Test Case C.3.8. The RFC 3315 Dynamic Host Configuration Protocol (DHCP) for IPv6 enables DHCP servers to pass configuration parameters such as IPv6 network addresses to IPv6 nodes. The HP Integrity RX2660 server running the SUSE Linux Enterprise Server 10 SP 2 OS met the test requirement.

Test Case C.1.13. The RFC 4291 IPv6 Addressing Architecture defines the specifications for the addressing architecture of the IPv6 protocol. The definitions cover unicast addresses, anycast addresses, and multicast addresses. The HP Integrity RX2660 server running the SUSE Linux Enterprise Server 10 SP 2 OS met the test requirement.

Test Case C.1.11. The RFC 4007 IPv6 Scoped Address Architecture defines the nature and characteristics for the usage of IPv6 addresses of different scopes. The HP Integrity RX2660 server running the SUSE Linux Enterprise Server 10 SP 2 OS met the test requirement.

Test Case C.1.12. The RFC 4193 Unique Local IPv6 Unicast Addresses defines globally unique local addresses. Local IPv6 unicast addressing is intended to be used for local communications and is not expected to be routed to the Internet. The HP Integrity RX2660 server running the SUSE Linux Enterprise Server 10 SP 2 OS met the test requirement.

Test Case C.1.8. The RFC 2710 Multicast Listener Discovery (MLD) for IPv6 specifies the protocol used by an IPv6 router to discover the presence of multicast listeners (i.e., nodes wishing to receive multicast packets) on its directly attached links, and to discover specifically which multicast addresses are of interest to those neighboring nodes. The HP Integrity RX2660 server running the SUSE Linux Enterprise Server 10 SP 2 OS met the test requirement.

Test Case C.1.10. The RFC 3810 MLD Version 2 for IPv6 adds support for “source filtering”, when compared to MLD Version 1, i.e., the ability to listen to packets ‘only’ from specific source addresses, or from ‘all but’ specific source addresses. The HP Integrity RX2660 server running the SUSE Linux Enterprise Server 10 SP 2 OS met the test requirement.

Test Case C.1.5. The RFC 2464 Transmission of IPv6 Packets over Ethernet Networks specifies the frame format for transmission of IPv6 link-local addresses and statelessly auto-configured addresses on Ethernet networks. The HP Integrity RX2660 server running the SUSE Linux Enterprise Server 10 SP 2 OS met the test requirement.

b. IP Security (IPSec).

Test Case C.2.1. The RFC 4301 defines the security architecture for IP. The document defines what IPSec is and how it works. The HP Integrity RX2660 server running the SUSE Linux Enterprise Server 10 SP 2 OS met the test requirement.

Test Case C.2.2. The RFC 4302 IP Authentication Header (AH) is used to provide connectionless integrity and data origin authentication for IP datagrams, and provides protection against replays. The HP Integrity RX2660 server running the SUSE Linux Enterprise Server 10 SP 2 OS met the test requirement.

Test Cases C.2.3 and C.2.8. In the RFC 4303 IP Encapsulating Security Payload (ESP), the ESP header is designed to provide a mix of security services in IPv4 and IPv6. The HP Integrity RX2660 server running the SUSE Linux Enterprise Server 10 SP 2 OS met the test requirement.

Test Cases C.2.4 and C.2.8. The RFC 4305 Cryptographic Algorithm Implementation defines the requirements for ESP and AH. The HP Integrity RX2660 server running the SUSE Linux Enterprise Server 10 SP 2 OS met the test requirement.

Test Cases C.2.5. The RFC 4306 Key Internet Exchange (IKE) Version 2 (IKEv2) Protocol describes the IKEv2 protocol and its use for performing mutual authentication and establishing and maintaining Security Associations. The HP Integrity RX2660 server running the SUSE Linux Enterprise Server 10 SP 2 OS met the test requirement.

Test Case C.2.6 The RFC 4307 Cryptographic Algorithms for Use in the IKEv2 defines the current set of algorithms that are mandatory to implement as part of IKEv2, as well as those algorithms likely to become mandatory in the future. The HP Integrity RX2660 server running the SUSE Linux Enterprise Server 10 SP 2 OS met the test requirement.

Test Case C.3.7. The RFC 3041 Privacy Extensions for Stateless Address Auto Configuration in IPv6 describes the process for Stateless address auto-configuration whereby the interface of a network device is manufactured with an embedded Institute of Electrical & Electronics Engineers, Inc. identifier which, when connected to a network, is automatically appended to the Link Local and router-provided network prefixes to produce functional network addresses for that interface. The HP Integrity RX2660 server running the SUSE Linux Enterprise Server 10 SP 2 OS met the test requirement.

Test Cases C.2.4 and C.2.8. The RFC 4308 Cryptographic Suites for IPsec define how security algorithms provide privacy and authentication between the initiator and responder. The HP Integrity RX2660 server running the SUSE Linux Enterprise Server 10 SP 2 OS met the test requirement.

c. Transition Mechanisms.

Test Case C.3.18. The RFC 4213 Transition Mechanisms for IPv6 Host and Routers specifies IPv4 co-existence mechanisms that can be implemented by IPv6 devices. The HP Integrity RX2660 server running the SUSE Linux Enterprise Server 10 SP 2 OS met the test requirement.

d. Server.

Test Case Not Applicable (N/A). The RFC 2616 Hypertext Transfer Protocol is an application level protocol used for distributed, collaborative, hypermedia information systems. The HP Integrity RX2660 server running the SUSE Linux Enterprise Server 10 SP 2 OS met the test requirement.

Test Case N/A. The RFC 4330 Simple Network Time Protocol (SNTP) Version 4 for IPv4, IPv6 and Open Systems Interconnect - Network Time Protocol (NTP) Server and Client Role specifies the basic protocol for the Internet NTP. The NTP server gives the client the requested time including offset and stratum. The functionality of the SNTP was tested by setting up an SNTP server and requesting SNTP traffic from a client. The HP Integrity RX2660 server running the SUSE Linux Enterprise Server 10 SP 2 OS met the test requirement.

Test Case N/A. The RFC 959 File Transfer Protocol (FTP) defines how computers can transfer files between devices. The HP Integrity RX2660 server running the SUSE Linux Enterprise Server 10 SP 2 OS met the test requirement.

Test Case N/A. The RFC 2428 FTP Extensions for IPv6 and Network Address Translations specify that a Server must be capable of transferring files with IPv6 and support Extended Data Port (EPRT) and Extended Passive (EPSV) commands. The functionality of the FTP was tested by setting up an FTP server with EPRT, then EPSV enabled and sent FTP traffic to and from a client. The HP Integrity RX2660 server running the SUSE Linux Enterprise Server 10 SP 2 OS met the test requirement.

Test Case N/A. The RFC 2821 Simple Mail Transfer Protocol (SMTP) provides transfer of e-mail reliably and efficiently. The SMTP is independent of the particular transmission subsystem and requires only a reliable ordered data stream channel. The HP Integrity RX2660 server running the SUSE Linux Enterprise Server 10 SP 2 OS met the test requirement.

e. Host.

Test Case C.3.12. The RFC 3484 Default Address Selection for IPv6 describes two algorithms, for source address selection and for destination address selection. The algorithms specify *default* behavior for IPv6 implementations. They do not override choices made by applications, upper-layer protocols, or locally administrated policy. The HP Integrity RX2660 server running the SUSE Linux Enterprise Server 10 SP 2 OS met the test requirement.

Test Case C.3.13. The RFC 3596 Domain Name Server (DNS) Extensions to Support IPv6 defines the changes to DNS necessary to support hosts running IPv6. The extensions are designed to be compatible with existing applications and DNS implementations. The HP Integrity RX2660 server running the SUSE Linux Enterprise Server 10 SP 2 OS met the test requirement.

Test Case C.3.17. The RFC 3986 Uniform Resource Identifier (URI) Generic Syntax defines a generic URI syntax and a process for resolving URI references. The HP Integrity RX2660 server running the SUSE Linux Enterprise Server 10 SP 2 OS met the test requirement.

f. Conclusion. The HP Integrity RX2660 server running the SUSE Linux Enterprise Server 10 SP 2 OS met all the required RFCs.

12. TEST AND ANALYSIS REPORT. No detailed test report was written in accordance with guidance from the Assistant Secretary of Defense-Networks Information and Integration. All test data is maintained in the Advanced IP Technology Capability and is available upon request. This certification is available on the Joint Interoperability Tool (JIT). The JIT homepage is <http://jit.fhu.disa.mil> (NIPRNet), or <http://199.208.204.125/> (SIPRNet). The JIT has links to JITC interoperability documents to provide the DoD community, including the warfighter in the field, easy access to the latest interoperability information. System interoperability status information is available via the JITC System Tracking Program (STP). The STP is accessible by .mil/.gov users on the NIPRNet at: <https://stp.fhu.disa.mil/>.